

## MINIATURE BUTTON TYPE LOAD CELL

### DESCRIPTION :

SHARP Miniature Button Type Load Cell is designed for compact force measurement applications where space is limited. It offers high accuracy, stainless steel construction, and reliable performance in industrial environments.

This load cell is ideal for automation systems, testing machines, and industrial force measurement applications.

### (MINIATURE COMPRESSION LOAD CELL)



### FEATURE :

- Miniature Button Type Design
- Compact & Low Profile
- Stainless Steel Construction
- High Accuracy & Repeatability
- Long-Term Stability
- Easy Installation
- IP67 Protection (Optional)
- Rugged Industrial Design
- **Custom Design Available**

### APPLICATION :

- Industrial Force Measurement
- Automation Systems
- Testing Machines
- Press Force Monitoring
- Robotics Applications
- Packaging Machines
- Assembly Line Measurement
- OEM Equipment

### DIMENSION :

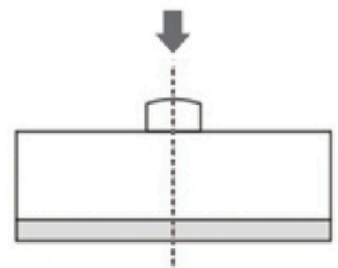
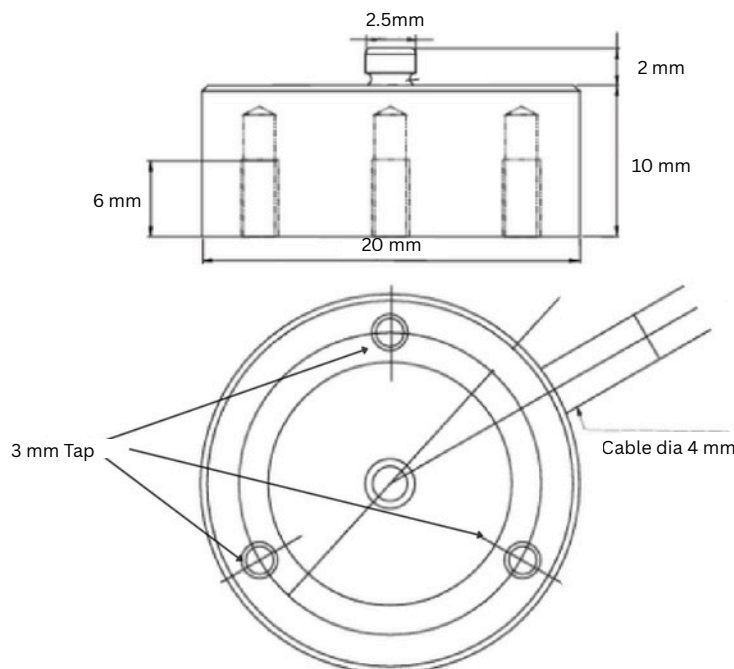

**LOAD APPLICATION LAYOUT**

## TECHNICAL SPECIFICATIONS :

Parameter	Specification
Type	Miniature Compression Load Cell
Model	SH-MBT Series
Rated Output	2.0 mV/V $\pm$ 0.25%
Accuracy Class	$\pm$ 0.1% F.S
Linearity	$\pm$ 0.1% F.S
Hysteresis	$\pm$ 0.1% F.S
Repeatability	$\pm$ 0.05% F.S
Safe Overload	150% F.S
Ultimate Overload	200% F.S
Input Voltage	5-15 V DC
Zero Balance	$\pm$ 1% F.S
Insulation Resistance	>5000 M $\Omega$
Operating Temperature	-10°C to +60°C
Storage Temperature	-20°C to +70°C
Material	Stainless Steel
Protection Class	IP65 / IP67

## AVAILABLE CAPACITIES :

Model	Capacity
SH-MBT-10	10 kg
SH-MBT-20	20 kg
SH-MBT-30	30 kg
SH-MBT-50	50 kg
SH-MBT-100	100 kg
SH-MBT-200	200 kg
SH-MBT-300	300 kg
SH-MBT-500	500 kg
SH-MBT-750	750 kg
SH-MBT-1000	1000 kg

## ADVANTAGES :

- Compact Size
- High Accuracy
- Long Life
- Easy Installation
- Industrial Grade Design

# SHARP ELECTRONICS

*The name of Quality*

[www.sharpelectronics.net](http://www.sharpelectronics.net)

[www.sharpweighingscale.com](http://www.sharpweighingscale.com)

**MANUFACTURER OF LOAD CELL AND WEIGHING SYSTEMS**

**CONTACT NUMBER: +91-9922147673 / 9422027933**

**+91-8888006677 / 9422328132**

**Email id : [purchasesharp@gmail.com](mailto:purchasesharp@gmail.com)**

DS Tower, Mahatma Phule Rd, Onkar Colony, Ratnadeep Colony, Yashoda Colony,  
Wakad, Pimpri-Chinchwad, Maharashtra 411033